

## PRECISION GRINDING MACHINES

### Center Hole Grinders

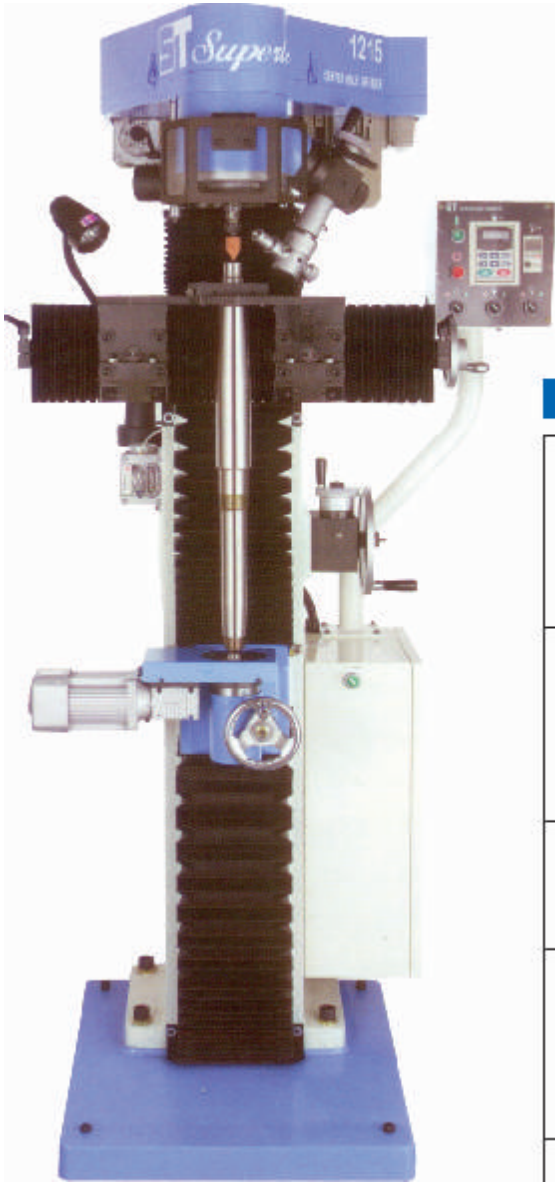

**CG-1215**

Unit:mm (inch)

DESCRIPTION/MODEL		CG-1015/ CG-1215
Workpiece	Diameter of workpiece	Ø5-Ø150(0.2"-6")
	Length of workpiece	50-1000(2"-40")/50-1200(2"-48")
	Max weight of workpiece	100kgs(220 lbs)
Grinding capacity	Cone angle of center holes	60°
	Diameter of center holes	Ø2-Ø50(0.08"-2")
	Planetary axis stroke	1.5(0.06")
Grinding spindle	Diameter of grinding wheel	Ø25(Ø1")
	Speed of grinding spindle	8000-20000 rpm
Motor	Grinding spindle motor	220V / 1.5 HP / 3 ph
	Planetary axis motor	220V / 100 W / 3 ph
	Dust collecton motor	220V / 0.5 HP / 3 ph
Vertical downfeed	Max. Stroke	200(8")
	Micro feed (handwheel per revolution)	0.125
	Micro feed (handwheel per graduation)	0.0125
Dressing device	Diamond dresser	80(3.2")
	Handwheel per revolution	1.5(0.06")
Electricity	Power source	220V, 50 / 60 Hz, 3 ph
	Electric power	1.5KVA
Weight	Net Weight	1000kgs (2200 lbs)